

VAMP Feeder/Motor Protection Relay VAMP 40





Main Characteristics

- **Complete Protection**

Comprehensive selection of protection functions for distribution network overhead line feeders, cable feeders, motor feeders including large motors, capacitor banks and reactors.

- **Comprehensive Measurements**

Wide range of measurement functions including phase and residual currents, residual or line or phase voltage, frequency, current unbalance, maximum demand, negative phase sequence current, active and reactive power and energy according to the primary connection.

- **Power Quality Assessment**

Power quality assessment and analysis including supervision of harmonics up to the 15th order, THD of currents and voltage.

- **Ultra-fast Arc Protection**

Unique integrated arc fault protection functionality for enhanced safety of switchgear and substations to people and property.

- **Extensive Communication**

Large number of supported communication protocols including IEC 60870-5-103, Modbus TCP, Modbus RTU, Profibus DP, TCP/IP, SPA-bus slave, DNP 3.0 and IEC 61850*.

- **Easy Handling and Management**

Easy commissioning, configuration and operation of the relays supported by the straight-forward VAMPSET relay management software.

- **Limited Depth Dimension**

The slim casing gives a possibility to install this relay to the secondary equipment compartment which has limited space.

- **Universal auxiliary power supply**

The wide auxiliary power supply, 18-265 V ac/dc, 50/60 Hz makes this relay suitable to every installation.

*) future software release

Application

The protection relays of the VAMP Series are used for the selective protection of overhead line feeders, cable feeders, motor feeders, capacitor banks, reactors and busbars in power system distribution substations, power plants, industrial power systems, marine and offshore installations. Besides a comprehensive range of standard protection functions the VAMP series also offers measurement, primary circuit monitoring and communication functionality.

A unique feature of the VAMP relays is the arc fault protection system integrable into the relays. The extremely fast arc fault protection option adds a new dimension to the total safety of the installation and the reliability of the protection system.

Customer specific configuration is obtained by programming the device using keypad or VAMPSET software.

After a network fault the relays support a subsequent fault analysis by providing event sequence (200 events) recordings, fault value registration and disturbance recorder capability.

All this functionality and a comprehensive set of supported communication protocols make the VAMP Series an outstanding product portfolio on the world market of power system protection and control equipment.



Measurement and Monitoring Functions

The VAMP 40 offers a complete set of measurement functions to replace the conventional metering functions of traditional switchgear and control gear installations. The measurement functions cover currents, residual or phase to phase or phase to earth voltages. The voltage measurement vary according to the connected voltage that is either residual voltage (U_0), phase to earth voltage (UL1) or phase to phase voltage (U12) connection. The measured information can be read via the communication bus or display.

Besides the measurement functions VAMP 40 also encompasses a set of system supervision functions. All current circuits are continuously supervised, as are the trip circuits from the relay to the circuit breaker trip coils. The wear and tear of the circuit breaker is also continuously monitored providing an alarm when the circuit breaker needs maintenance.

Power Quality Assessment

The power quality of electrical networks has become increasingly important in modern society. Sophisticated loads, such as computers and automation systems, require an uninterrupted supply of "clean" electricity.

The VAMP 40 feeder and motor protection relay is provided with integrated power quality measuring and analyzing functions, which help catching possible variations in the quality of the distributed power. The relay supervises harmonics of phase currents and one voltage from the 2nd to 15th order and the THD (Total Harmonic Distortion).

Many functions in modern society rely heavily on electric energy and therefore the quality of the energy supply is gaining increased importance



Functionality

Protection functions		
IEEE no	IEC symbol	Function name
50/51	$3I>, 3I>>, 3I>>>$	Overcurrent protection
50N/51N	$I_0>, I_0>>, I_{02}>, I_{02}>>$	Earth fault protection
67N	$I_{\varphi}>, I_{0\varphi}>>$	Directional earth fault protection ⁽¹⁾
REF	I_{0REF}	Restricted earth fault protection
46	$I_2/I_1>$	Broken conductor protection
46	$I_2>$	Unbalance protection
47	$I_2>>$	Phase reversal / incorrect phase sequence protection
48	$I_{st}>$	Stall protection
66	$N>$	Frequent start protection
37	$I<$	Undercurrent protection
49	$T>$	Overload protection
32	$P<$	Reverse power, 1 phase
59N	$U_0>, U_0>>$	Residual voltage protection ⁽¹⁾
59	$U>, U>>, U>>>$	Overvoltage protection, 1-phase ^(2, 4)
27	$U<, U<<, U<<<$	Undervoltage protection, 1-phase ^(2, 4)
68	2.ha	Second harmonic stage /inrush
79		Auto reclose function
50BF	CBFP	Circuit-breaker failure protection
50AR	ArcI>	Arc fault protection ^(3, 4)
		Capacitor bank unbalance protection
86		Latched trip
		Programmable stages 1 ... 8

Measurement and monitoring functions		
	$3I$	Three-phase current
	I_0	Neutral current
	I_2	Current unbalance
	I_L	Average and maximum demand current
	U_0	Residual voltage
	UL1 / U12	Phase to earth and phase to phase voltages ^(2, 4)
	P	Active power ^(2, 4)
	Q	Reactive power ^(2, 4)
	S	Apparent power ^(2, 4)
	E+, E-	Active energy, exported / imported ^(2, 4)
	Eq+, Eq-	Reactive energy, exported / imported ^(2, 4)
	PF	Power factor
	f	System frequency
		Phasor diagram views of currents, residual ⁽¹⁾ or phase or line voltages ⁽²⁾
		2nd to 15th harmonics and THD of currents
		Condition monitoring CB wear
		Condition monitoring CT supervision
		Trip Circuit Supervision (TCS)
		Disturbance recorder
		Temperature
		CB control

Communication		
		IEC 60870-5-103
		Modbus TCP
		Modbus RTU
		Profibus DP
		SPA-bus
		DNP 3.0
		DNP 3.0 TCP
		Human Machine Interface, display
		Human Machine Interface, PC
		Migration path to IEC 61850 ⁽⁴⁾

Hardware		
		Number of phase current CT's 3
		Number of residual current CT's 2
		Number of voltage input VT's 1
		Number of digital inputs 2
		Number of trip outputs 4
		Number of alarm outputs 1
		Internal Failure, IF (NO/NC) 1
		RTD inputs 4-16 ⁽³⁾

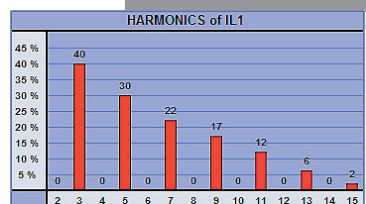

Example of harmonics content obtained from a VAMP 40 relay.

1) with residual voltage connection
 2) with phase to phase or phase to earth voltage connection
 3) option 4) future software release

Arc Protection

Whether the time-grading or blocking based protection coordination principle is used, the traditional protection systems may not provide fast enough protection of substation faults. Further, high-impedance type of earth-faults may cause prolonged operation times of earth-fault relays leading to the significant release of the arcing energy. These facts pose a considerable risk to human beings and economical assets. By applying a modern, high-speed arc protection system the damage may be considerably reduced. Such an arc protection system is an optional feature incorporatable in all current measuring VAMP relays.

The VAMP relays measure the fault current. If the arc protection interface option is selected the relays also

measure light via arc sensor channels monitoring the whole switchgear. Should an arcing fault occur in the switchgear the arc protection system provides an extremely fast tripping of the circuit breaker.



Traditional protection relay systems do not provide fast enough protection in an arc-fault situations.

The VAMP 40 protection relay with integrated arc protection also provide a cost efficient high-speed MV busbar protection.

VAMPSET Setting and Configuration Tool

VAMPSET is a user-friendly, **free-of-charge** relay management software for setting, parameterization and configuring of VAMP relays. Via the VAMPSET software relay parameters, configurations and recorded relay data can be swapped between the operator's PC and the VAMP relays. Supporting the COMTRADE format VAMPSET also incorporates tools for analyzing relay events, waveforms and trends from data recorded by the relays, e.g. during a network fault situation.

Using a standard RS cable the PC running VAMPSET connects to the front or rear port of the VAMP relays. The VAMPSET software also supports TCP/IP communication via an optional 10Base-T connection. Featuring true **multi-language support** the software runs on Windows XP/2000/NT and Windows 98/95 without any need for configuration of the PC.



The motor start-up register stores the motor start-up values (start current, duration etc.) significantly facilitating the correct setting of the relay even if critical motor data are unavailable from the manufacturer.

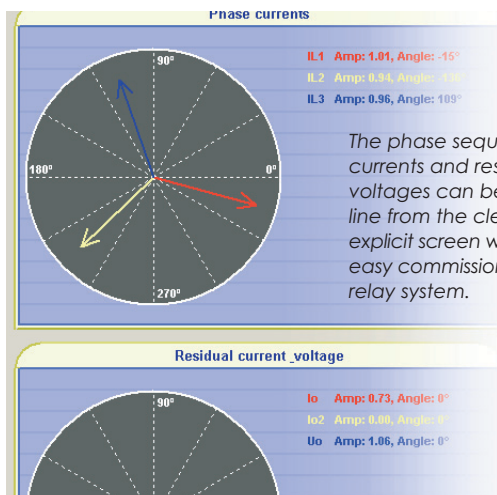

The phase sequences for currents and residual voltages can be read on-line from the clear and explicit screen windows for easy commissioning of the relay system.

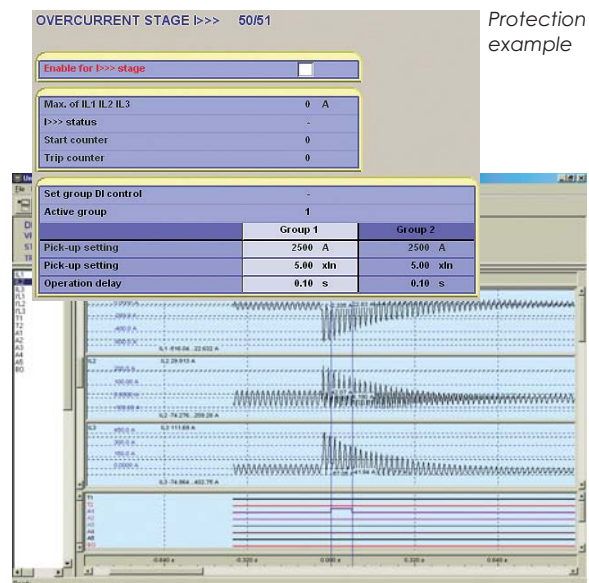

Protection setting example

As a regular feature of the VAMP relays standard COMTRADE type disturbance recording files can be uploaded for subsequent evaluation of any network event recorded.

Applications

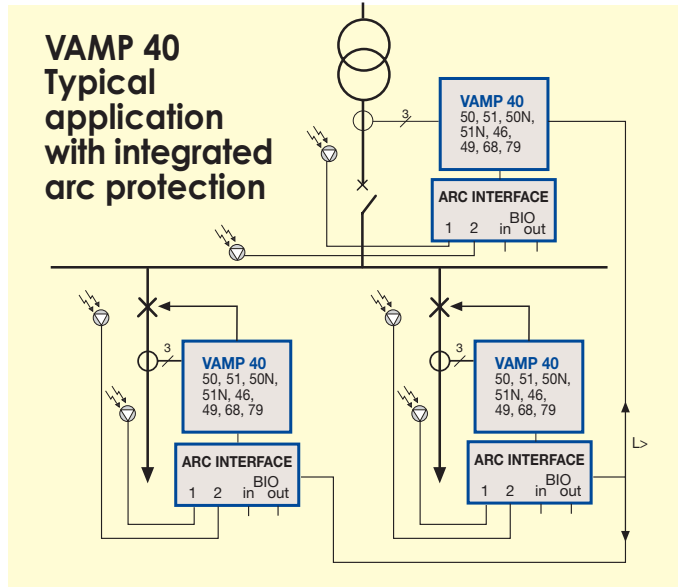
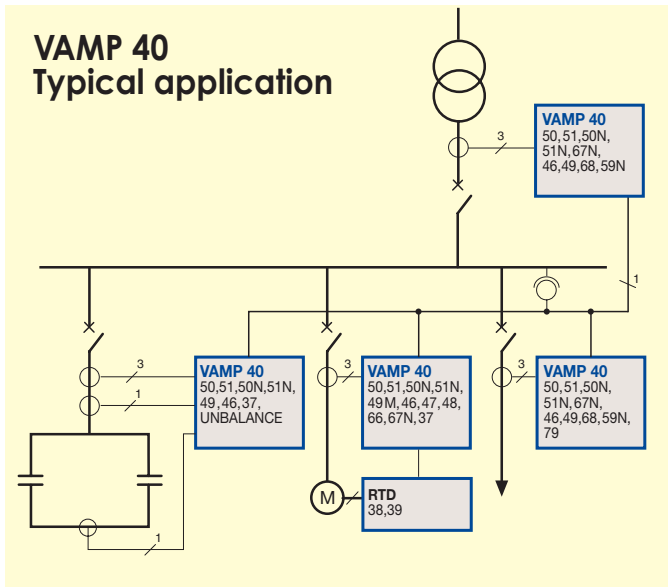

Dimensional Drawings

The slim casing gives a possibility to install this relay to the secondary equipment compartment which has limited space.

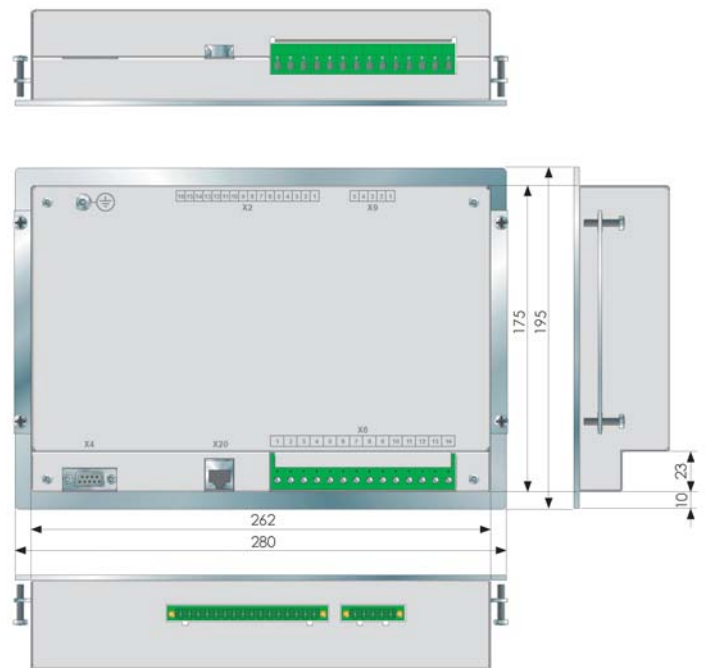
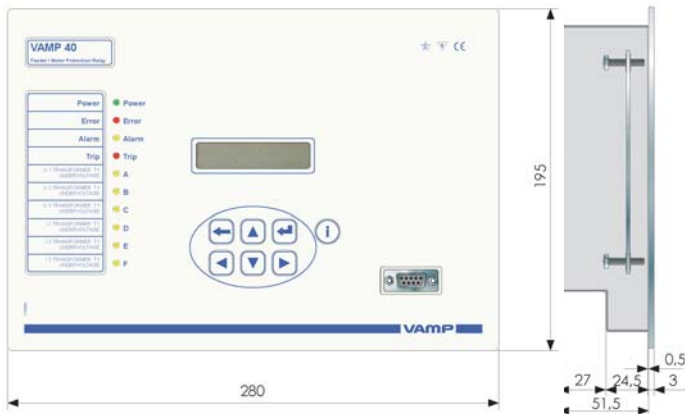

Order Codes

Order Code	Explanation	Note
VAMP 40	Feeder / motor protection relay	VAMP Ltd

Accessories

VEA 3 CG	Ethernet Interface Module	VAMP Ltd
VPA 3 CG	Profibus Interface Module	VAMP Ltd
VSE001	Fiber optic Interface Module	VAMP Ltd
VSE002	RS485 Interface Module	VAMP Ltd
VX003-3	Programming Cable (VAMPSET, VEA3CG+200-series)	Cable length 3m
VP40	Arc option ¹⁾	Vamp Ltd
VA1DA-6	Arc Sensor, cable length 6 m	VAMP Ltd
DI-934MB	RTD Input module ²⁾	DataQ Instruments Inc.
Adam 4015-B	RTD Input module ²⁾	Advantech Co., Ltd

1) future software release
2) disable use of remote protocol communication

Panel cut-out

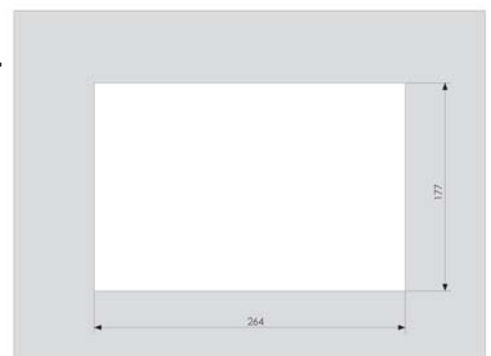

Technical Data, Tests and Environmental Conditions



Measuring circuitry

Rated current In	1...10 A (software parameter)
- Current measuring range	0...250 A (0...50) x In [In=5 A]; 0...250 x In [In=1 A]
- Thermal withstand	20 A (continuously) 100 A (for 10 s) 500 A (for 1 s)
- Burden	< 0.2 VA
Rated current Ion	1/5 A
- Current measuring range	0...10 A (0...10) x Ion
Rated current Io2n	0.2/1 A
- Current measuring range	0...50 A (0...10) x Io2n
Rated voltage Uon / Un	50 - 120 V (configurable)
- Voltage measuring range	0 - 175 V (100 V/110 V)
- Continuous voltage withstand	250 V
- Burden	< 0.5V A
Rated frequency fn	50 / 60 Hz (45 - 65 Hz)
- Frequency measuring range	16 - 75 Hz
Terminal block:	Maximum wire dimension:
- Solid or stranded wire	4 mm ² (10-12 AWG)

Auxiliary voltage

Rated voltage Uaux	18 - 265 V ac/dc 110/120/220/240 V ac 24/36/48/60/110/125/220 V dc
Power consumption	< 7 W (normal conditions) < 15 W (output relays activated)
Max. permitted interruption time	< 50 ms (110 V dc)
Terminal block:	Maximum wire dimension:
- Phoenix MVSTBW or equivalent	2.5 mm ² (13-14 AWG)

Digital inputs

Qty	2 pcs
Rated voltage	18 - 265 Vdc

Digital outputs

Trip relays	4 pcs
Alarm relays	1 pc
Internal fault relay	1 pc

Casing

Dimensions (W x H x D)	280 x 195 x 55
Weight	
(Terminal, Package and Manual)	5 kg

Disturbance tests

Emission	
- Conducted EN 55022B	0.15 - 30 MHz
- Emitted (CISPR 11)	30 - 1 000 MHz
Immunity	
- Static discharge (ESD)	IEC 60255-22-2, class III 6 kV contact discharge 8 kV air discharge
- Fast transients (EFT)	IEC 60255-22-4, class B 2 kV, 5/50 ns, 5 kHz, +/-
- Surge	IEC 60255-22-5 2 kV, 1.2/50 µs, line-to-earth 1 kV, 1.2/50 µs, line-to-line
- Conducted HF field	IEC 60255-22-6 0.15 - 80 MHz, 10 V/m
- Emitted HF field	IEC 60255-22-3 80 - 1000 MHz, 10 V/m
- GSM test	ENV 50204 900 MHz, 10 V/m, pulse modulated

Test voltages

Insulation test voltage	IEC 60255-5, class III 2 kV, 50 Hz, 1 min
Surge voltage	IEC 60255-5, class III 5 kV, 1.2/50 µs, 0.5 J

Mechanical tests

Vibration	IEC 60255-21-1, class I
Shock and pump	IEC 60255-21-2, class I

Environmental conditions

Operating temperature	-10 to +65 °C
Transport and storage temperature	-40 to +70 °C
Relative humidity	< 75% (1 year, average value) < 90% (30 days per year, no condensation permitted)





Vamp Ltd is a Finnish company specialized in developing and manufacturing protection relays for electrical power generation and distribution systems. Vamp Ltd offers complete MV protection and arc-protection family.

Our success is based on competitive standard products, constant development by our designers possessing experience from three protection relay generations, our long-term partnerships, flexibility and 24 hour care of our customers.

Our organization has been audited and found to be in accordance with the requirements of the ISO 9001:2000 management system.

Vamp Ltd is a member of the Vaasa Electronics Group Ltd.

Vamp Ltd	Visiting address:	Tel: +358 20 753 3200
P.O.Box 810	Vaasa Airport Park	Fax: +358 20 753 3205
FI-65101 VAASA	Yrittäjänkatu 15	Email: vamp@vamp.fi
Finland	Vaasa, Finland	http:// www.vamp.fi



We reserve the rights to product alterations without prior notice.
 Copyright © Vamp Ltd. All trademarks are the property of their respective holders.